

EXHAUST GAS DAMPERS

PRODUCT OVERVIEW

ENEVA Exhaust Gas Dampers are high-performance mechanical flow control devices designed to regulate, isolate or divert flue gas streams in industrial and energy systems.

They play a critical role in ensuring proper process control and efficient energy management, particularly in applications such as waste heat recovery systems, boiler operations and exhaust gas routing.

Designed for high temperature and demanding operating conditions, ENEVA dampers provide reliable performance, low leakage rates and optimized pressure drop, even in heavy-duty industrial environments.

MAIN ADVANTAGES

- Precise flow control, isolation and by-pass operation
- Designed for high temperature and high flow rate applications
- Low leakage rates with optimized sealing systems
- Engineered for minimum pressure drop
- Robust construction for harsh industrial environments
- Suitable for modulating or on-off operation
- Custom engineered according to project requirements
- Long service life with low maintenance needs



ENEVA ENGINEERING APPROACH



Each ENEVA damper is custom engineered based on process parameters such as gas temperature, flow rate, pressure and chemical composition.

Special design considerations include:

- Material selection according to corrosion and temperature conditions
- Aerodynamic design to minimize pressure drop
- Advanced sealing solutions to reduce leakage
- Structural design for long-term mechanical durability

Optional sealing air systems can be integrated for applications requiring near-zero leakage performance.

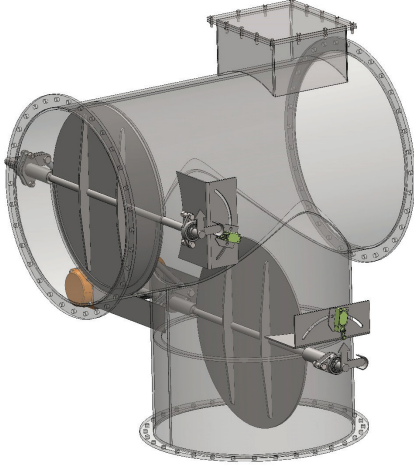

Design Temperature	Up to 600°C (higher on request)
Body Material	Carbon steel or stainless steel
Blade Type	Single blade / Multi blade
Sealing Options	Soft sealing / Metal-to-metal sealing
Actuator Type	Electric or pneumatic
Operation Mode	Operation Mode: On-Off or Modulating
Configuration	Configuration: Two-way or Three-way damper
Sealing Air System	Optional (for zero or ultra-low leakage)
Design	Flanged connection for easy installation
Additional Equipment	Position switch, limit switch, position indicator, manual override, manhole

DESIGN AND WORKING PRINCIPLE

ENEVA exhaust gas dampers are installed directly on flue gas lines and operate by controlling the position of internal blades.

In three-way damper configurations, one flow path opens while the other closes at the same time, ensuring continuous and controlled process operation.

All designs are optimized to achieve low leakage ratios and minimal pressure loss.

The system works as follows:

- The damper blade (single or multi-blade) is positioned within the gas duct
- An actuator (electric or pneumatic) adjusts the blade angle
- The gas flow is regulated, restricted or completely shut off depending on process requirements
- In diverter (multi-way) applications, flow is directed between two lines simultaneously

TYPICAL APPLICATIONS

- Cogeneration and trigeneration systems
- Boiler and waste heat recovery systems
- Furnace and process stacks
- Cement plants
- Iron and steel industry
- Petrochemical facilities
- Biogas and landfill gas plants
- Combined cycle power plants

WHY ENEVA?

- Project-specific engineering and design
- Strong experience in energy and process systems
- In-house mechanical design and manufacturing capability
- High-quality production and testing standards
- Reliable solutions for critical industrial applications

www.enevaenerji.com.tr

HEAD OFFICE: Adnan Kahveci Mah., Sishane Sok., Zigana Tria Ofis Plaza, No : 3/2, Daire : C 45, Beylikduzu / Istanbul / TR

WORKSHOP: Cumhuriyet Mah., Zubeyde Hanim Cad., Uysal 2 San. Sitesi, D1, Corlu / Tekirdag / TR

T: +90 (212) 982 46 14 **E:** info@enevaenerji.com.tr